



ENVELOPE 2000[®]

ROUT & RETURN (RR) SYSTEM

**The Ultimate in Performance
in a Wet-Sealed System**

TECHNICAL MANUAL

- System Assembly
- Substrate Layouts
- CAD Sections/Details
- Physical Properties
- Performance Properties

SYSTEM ASSEMBLY

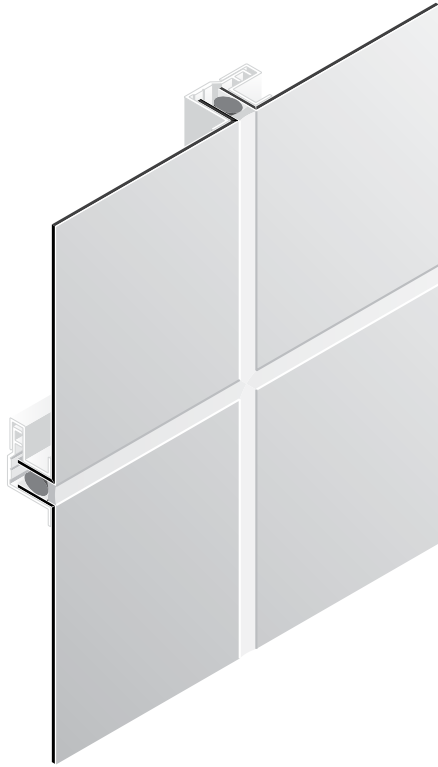

MATCHED CAULK

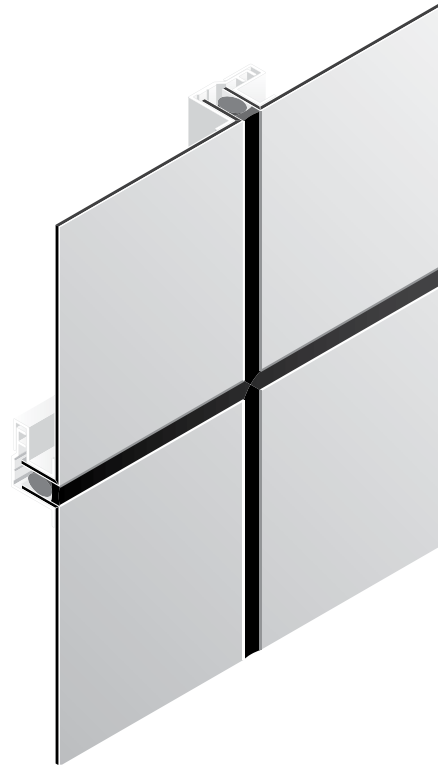

CONTRASTING CAULK

MOLDINGS / EXTRUSIONS

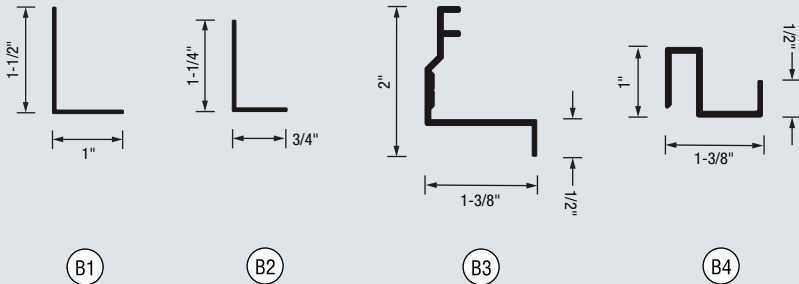

PROPERTIES

- B1** RR-103 Panel Clip
12'-6," 2.11 lbs
- B2** RR-104 End Run Angle
12'-6," 1.88 lbs
- B3** RR-121 Male Angle
12'-6," 4.69 lbs
- B4** RR-122 Female Angle
12'-6," 3.98 lbs

SUBSTRATE LAYOUT

NAILABLE SUBSTRATE

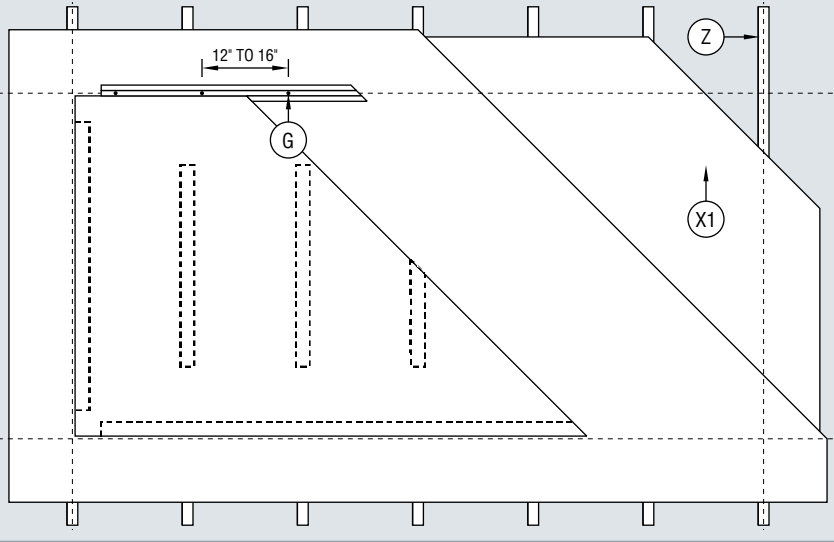

NON-NAILABLE SUBSTRATE

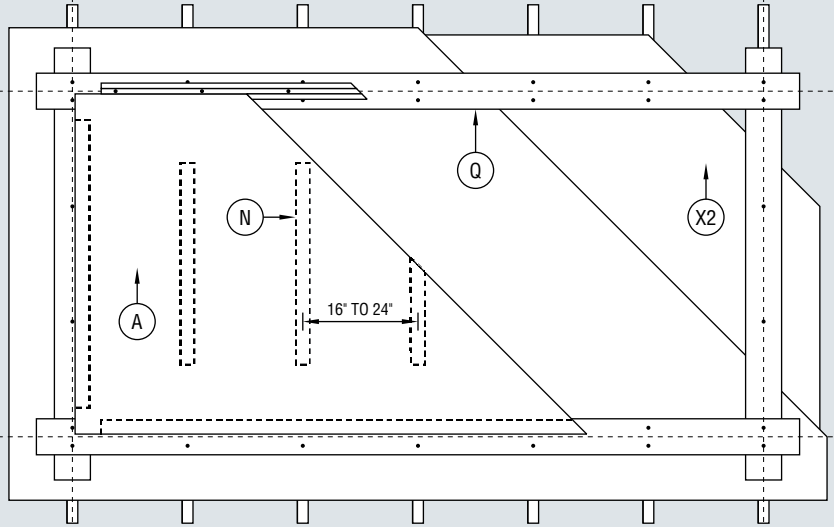

MASONRY SUBSTRATE

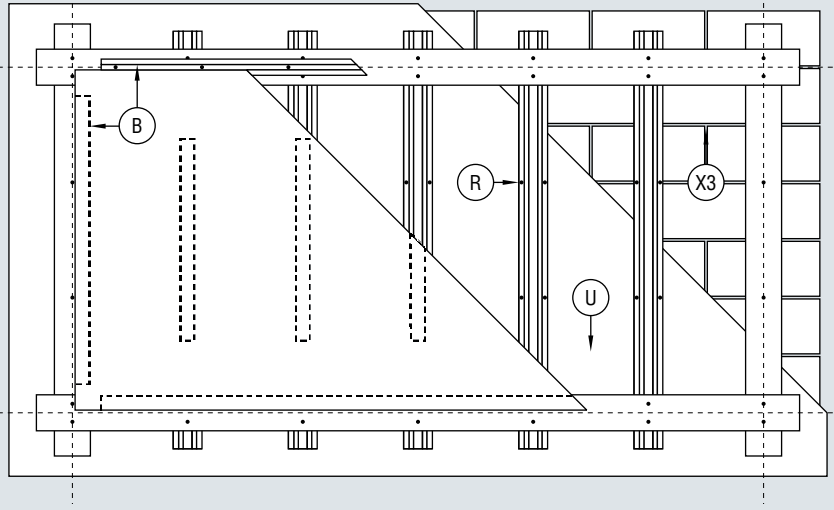

COMPONENTS

- A** Envelope 2000
- B** Extrusion
- G** Fastener
As selected by contractor to suit project requirements.
 - Panel - 12" to 16" around perimeter
 - Molding - 12" to 16" along length
- N** Stiffener
 - Located 16" to 24" o.c.
 - For panels 36" x 36" or larger
 - Length to be 2/3 panel height
- Q** Grid Strapping
 - 16ga (min) recommended
 - Fastened 12" to 16" along length
- R** Furring
 - Metal (hat channels, z-girts) or wood
 - Located 16" to 24" o.c.
 - Fastened 12" to 16" along length
- S** Shim (not shown)
 - Plastic shims recommended
 - Flatness tolerance is 1/4" in 20'-0"
- U** Air/Moisture Barrier
Recommended for this system.
- X1** Nailable Substrate
 - Plywood - 1/2" (min) recommended
 - OSB - 1/2" (min) recommended
- X2** Non-Nailable Substrate
 - Exterior gypsum board
- X3** Masonry Substrate
 - CMU (block)
 - Pre-formed concrete
- Z** Stud Framework
 - Metal or wood
 - Located 16" to 24" o.c.

NOTE: Combine both SECTION and SUBSTRATE drawings for a complete listing of components.

LAYOUT AND INSTALLATION

DESCRIPTION

- **Shop Fabricated** - preliminary steps (shop drawings, field measurements) are performed and then the panels are fabricated prior to arriving at the job site.
- **Barrier Wall** - designed to be completely sealed against moisture intrusion to protect the structural wall assembly of the building.
- **Progressive** - each step of the installation process builds off the previous step in a sequential manner, moving up and across the elevation.
- **Joints** - in between fabricated 'pans', a backer rod is placed along with silicone sealant to complete the joint.

Comparative Installed Cost



Lead Time:	6-8 weeks
Minimum Qty:	none
System Depth:	1-1/2" from the face of the substrate to the face of the panel

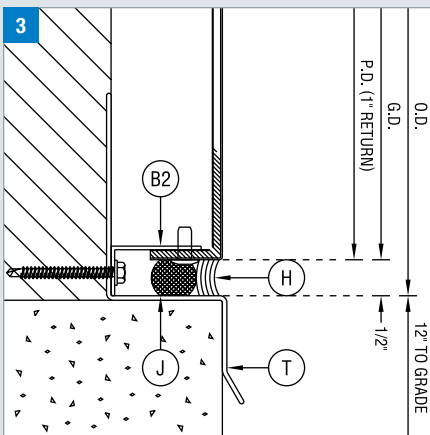
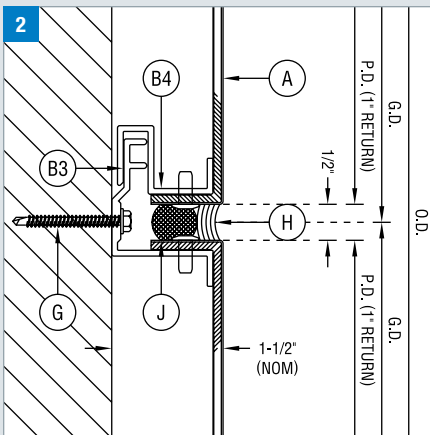
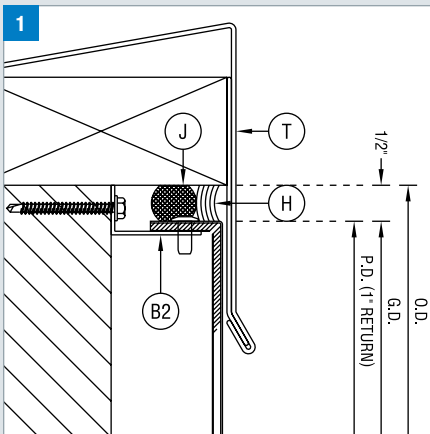

HORIZONTAL SECTIONS

1: Parapet

Metal flashing secured over blocking completes the vertical run and prevents moisture from getting behind the cladding system.

2: Horizontal

The lower fabricated 'pan' assembly is mechanically fastened to the substrate. The upper pan is then slid over the mounted extrusion and 'floats'. A foam backer rod and silicone sealant complete the joint.

3: Base / Foundation

Installation typically begins at the base of the wall and moves vertically. The cladding should be kept approximately 12" away from landscaping grade. However, if the system is installed adjacent to a concrete sidewalk, that dimension may be reduced to 1/2".

INSIDE CORNER

4: Inside Corner

As a shop fabricated system, there are no visible moldings. As a result, all corners are routed and bent within a shop setting. This condition is also applicable for wall to soffit transitions.

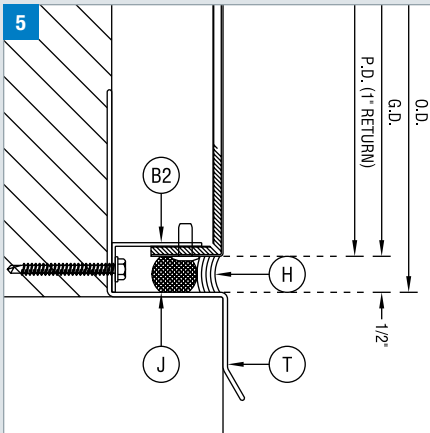
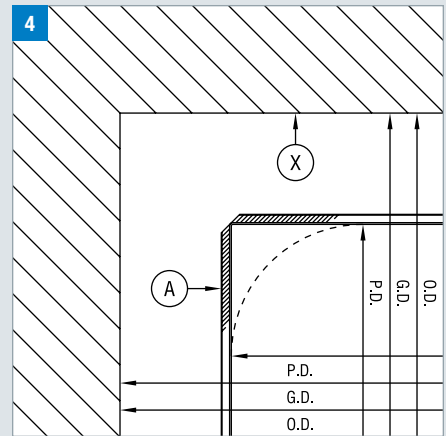

WINDOW HEAD & SILL

5: Head

Similar to the base condition, flashing should be used behind the system to direct water away and prevent moisture intrusion.

6: Sill

Depending upon visual preference, windows will either extend past the face of the panel or be aligned so that they sit flush. A backer rod and sealant complete the joint.

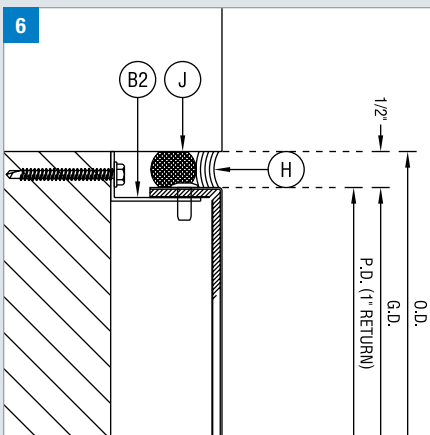

LAYOUT AND INSTALLATION

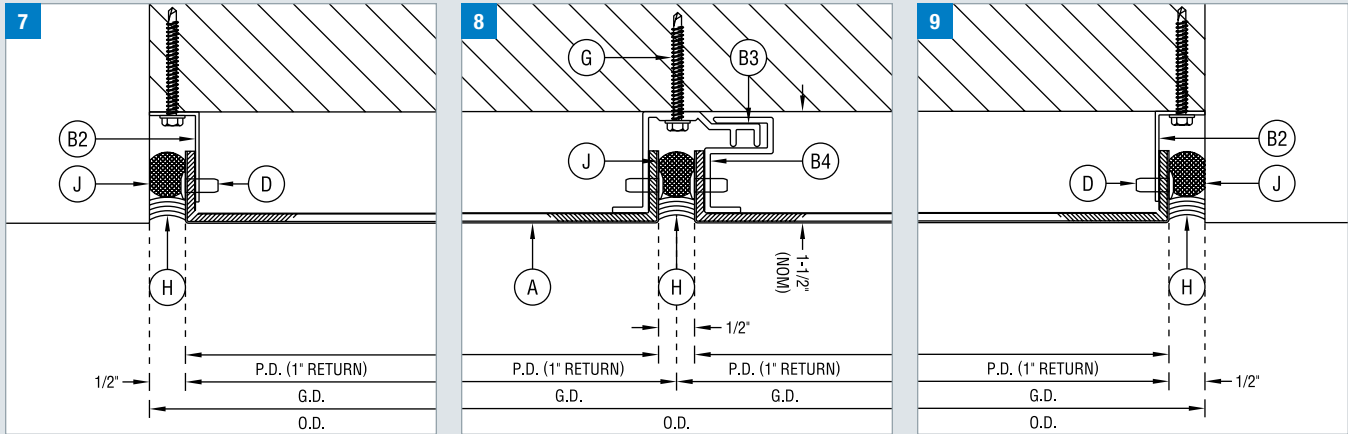

VERTICAL SECTIONS

7 & 9: Jamb

When abutting dissimilar material, a sealant joint should be used to prevent moisture intrusion behind the cladding system.

8: Vertical

Same condition as the horizontal, the first panel is secured into place and then the next panel is slid over the extrusion. The typical joint is 1/2" wide.

OUTSIDE CORNER

10: Outside Corner

As a shop fabricated system, there are no visible moldings. As a result, all corners are routed and bent within a shop setting. This condition is also applicable for fascia to soffit transitions.

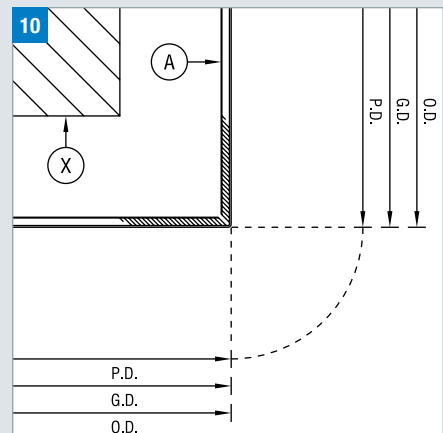

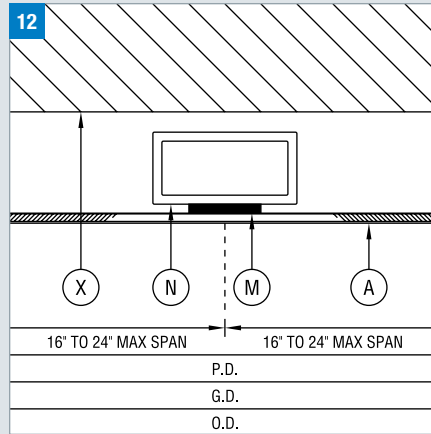
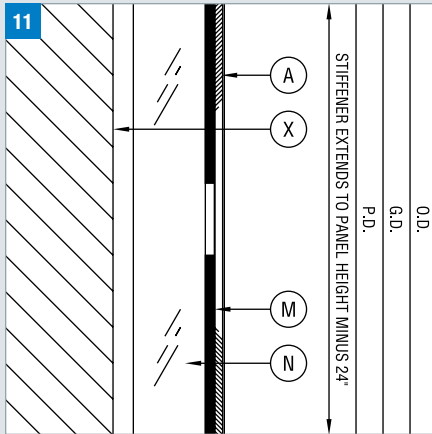

INTERMEDIATE CONNECTION

11: Intermediate Connection - Horiz

As a fabricated system, the field of the panel is not secured to the substrate. Rather, stiffeners are located at intermediate connections to provide panel support. The length of this stiffener should extend to cover a majority of the panel.

12: Intermediate Connection - Vert

The spacing of the stiffener may be dependent upon the overall size of the panel.

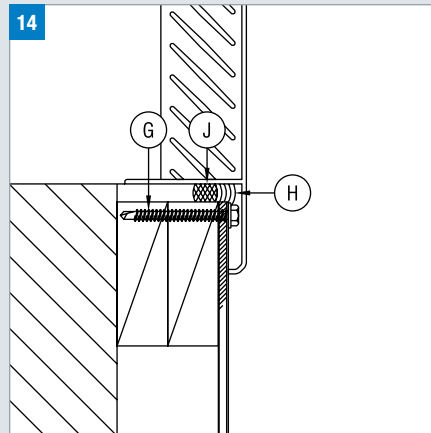
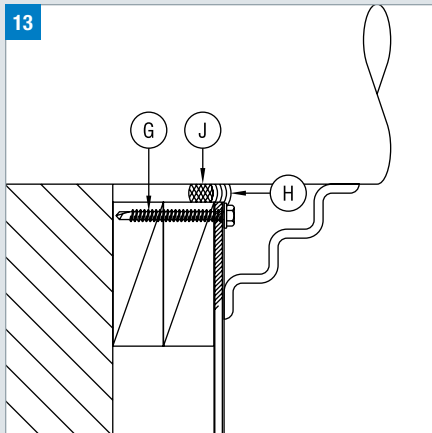

SYSTEM PENETRATIONS

13: Round

When piping or other round penetrations must occur, the hole should be made slightly larger to accommodate a backer rod (when possible) and sealant joint around the object.

14: Linear (Square or Rectangular)

A proper sealant joint should be utilized to maintain system integrity.

COMPONENTS

- A** Envelope 2000
- B1** RR-103 Panel Clip (not shown)
- B2** RR-104 End Run Angle
- B3** RR-121 Male Angle
- B4** RR-122 Female Angle
- C** PF-204 Reinforcement (not shown)
- D** Pop Rivet
- G** Fastener
As selected by contractor to suit project requirements.
 - Panel - 12" to 16" around perimeter
 - Molding - 12" to 16" along length
- H** Silicone Sealant
An approved sealant must be used. Contact Citadel for current list.
- J** Foam Backer Rod
- M** Adhesive Foam Tape (Double-Sided)
- N** Stiffener
 - Located 16" to 24" o.c.
 - For panels 36" x 36" or larger
 - Length to be 2/3 panel height
- T** Flashing
- X** Substrate
As selected by architect to suit project requirements.

NOTE: Combine both SECTION and SUBSTRATE drawings for a complete listing of components.

ENVELOPE 2000 ROUT & RETURN (RR) SYSTEM

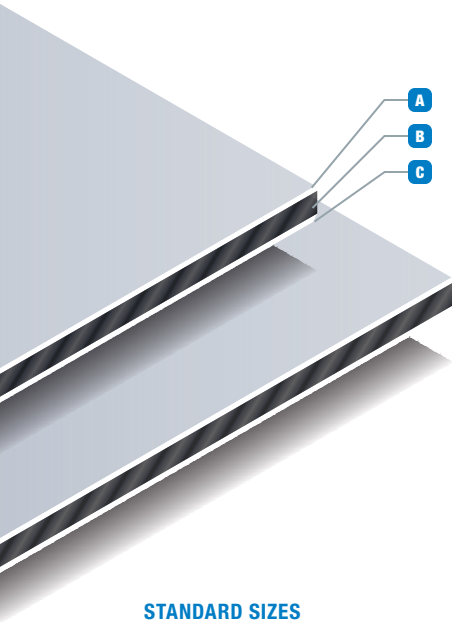

STANDARD SIZES

48" x 96"	(121.9cm x 243.8cm)
48" x 120"	(121.9cm x 304.8cm)
48" x 144"	(121.9cm x 365.8cm)
60" x 96"	(152.4cm x 243.8cm)
60" x 120"	(152.4cm x 304.8cm)
60" x 144"	(152.4cm x 365.8cm)

Cut-to-size panels are available in any increment up to 60" x 144."

WARRANTY

Panel Composition:	10 years
Kynar 500 Finishes:	30 years
Anodized Finishes:	20 years

RECYCLED CONTENT (BY WEIGHT)

Post-Consumer:	0.5%
Post-Industrial:	23.3 to 23.9%

BENDING / CURVING

Panels and extrusions may be curved in a factory setting.

Minimum Radius: 12"

MATERIAL PROPERTIES

Component	Standard (in)	Metric (mm)
A. Prefinished Smooth Aluminum ¹	.024"	0.61mm
B. Thermoset Phenolic Resin	.105"	2.68mm
C. Primed Smooth Aluminum	.010"	0.25mm

PANEL PROPERTIES

Property	Standard (in)	Metric (mm)
Panel Weight	1.25 lbs/ft ²	6.12 kg/m ²
Nominal Thickness ²	1/8"	4mm
Thickness Tolerance	±1/32"	±0.79mm
Length & Width Tolerance	+0, -1/8"	+0, -3.18mm
Squareness	1/64" Per Lineal ft	
Flatness	Visually Flat	

FINISH PROPERTIES

Finish	Type	Coating
Smooth Kynar 500®	2-coat PVDF (Solid, Mica)	0.20 mil Primer + 0.80 mil Color
	3-coat PVDF (Metallic)	0.20 mil Primer + 0.80 mil Color + 0.70 mil Clear
Smooth Anodized	Exterior Standard No. 1 ³	0.20 mil to 0.45 mil (Depending on Color)

PANEL PERFORMANCE⁴

Property	Test	Value	Unit
Flame Spread	ASTM E84	Class A	---
Peel Strength	ASTM D1781	34.5	lb-in/lb
Ignition Temperature	ASTM D1929	900°	°F
Impact Resistance	ASTM D5420	On Request	

SYSTEM PERFORMANCE (ENVELOPE 2000 RR SYSTEM)⁴

Property	Test	Value
Air Infiltration	ASTM E283	Pass
Water Resistance	ASTM E331	Pass
Uniform Load	ASTM E330	Pass
Intermediate Scale Multi-Story ⁵	UBC 26-9	Pass

1 - Prefinished aluminum skins are furnished with a PVC film for protection during shipment and installation.

2 - 3mm, 6mm, and 8mm thicknesses are also available for use with the Rout & Return (RR) System.

3 - Class I or Class II anodizing is available as a premium custom finish. However, the warranty remains the same and fabrication difficulties will result (increased crazing, cracking) due to the increased film thickness.

4 - Other testing is available upon request.

5 - UBC 26-9 is equivalent to NFPA 285 (verified by third party lab).

Citadel Architectural Products

6198 W Airport Blvd
Greenfield, IN 46140
(800) 446-8828

www.citadelap.com • info@citadelap.com

AIA
Continuing
Education
Provider



MADE IN THE U.S.A.

Citadel Architectural Products has implemented a Quality Management System in accordance with ISO 9001:2015.