

A photograph of a modern building facade featuring a rainscreen system. The building has a mix of light grey and dark grey panels, with a prominent vertical window strip. The sky is blue with scattered white clouds.

ENVELOPE 2000[®]

RAINSCREEN (RS) SYSTEM

**The Ultimate in Performance
in a Dry-Joint System**

TECHNICAL MANUAL

- System Assembly
- Substrate Layouts
- CAD Sections/Details
- Physical Properties
- Performance Properties

SYSTEM ASSEMBLY

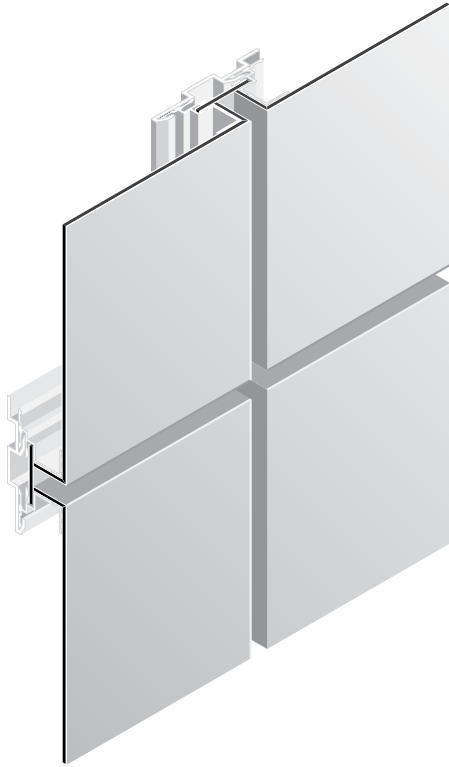

STANDARD JOINT

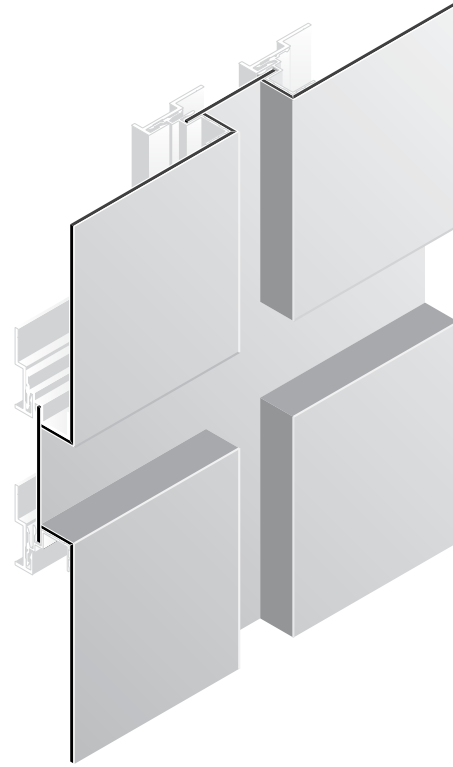

VARIABLE JOINT

MOLDINGS / EXTRUSIONS

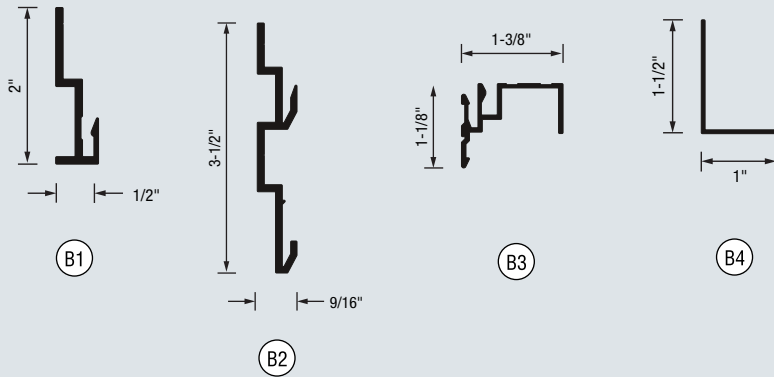

PROPERTIES

- B1** 8212 Starter
12'-6", 4.45 lbs
- B2** 8214 Hanger
12'-6", 7.50 lbs
- B3** 8216 Panel
12'-6", 3.56 lbs
- B4** RR-103 Panel Clip (not shown)
12'-6", 2.11 lbs

SUBSTRATE LAYOUT

NAILABLE SUBSTRATE

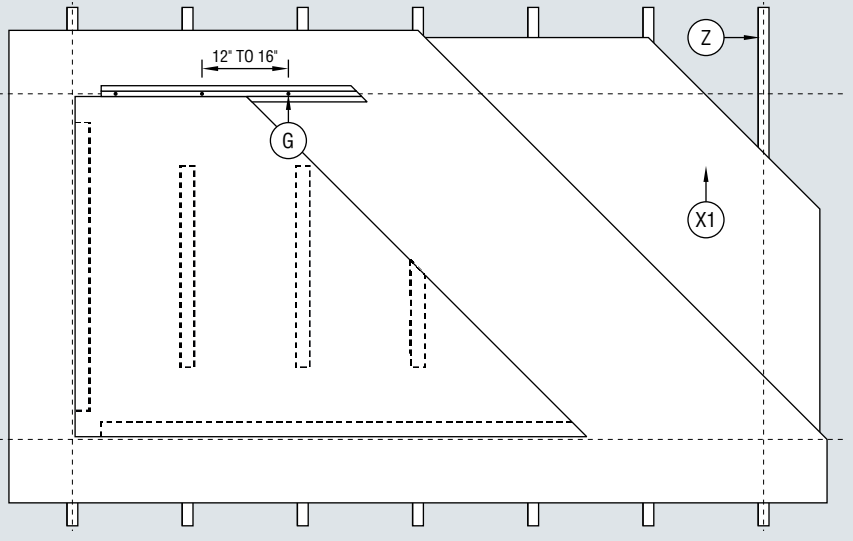

NON-NAILABLE SUBSTRATE

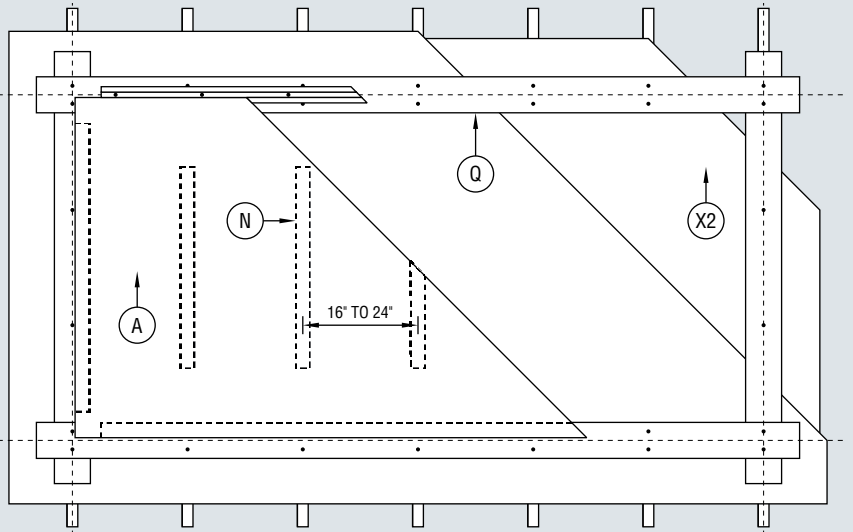

MASONRY SUBSTRATE

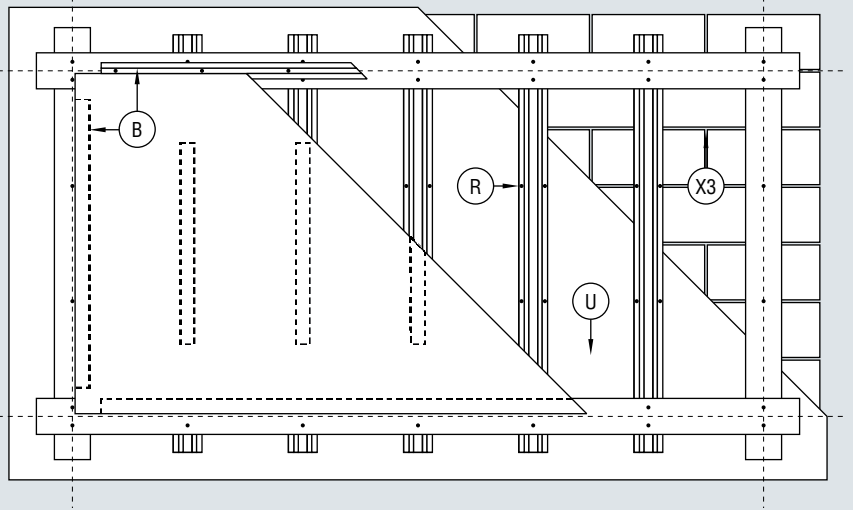

COMPONENTS

- A** Envelope 2000
- B** Extrusion
- G** Fastener
As selected by contractor to suit project requirements.
 - Panel - 12" to 16" around perimeter
 - Molding - 12" to 16" along length
- N** Stiffener
 - Located 16" to 24" o.c.
 - For panels 36" x 36" or larger
 - Length to be 2/3 panel height
- Q** Grid Strapping
 - 16ga (min) recommended
 - Fastened 12" to 16" along length
- R** Furring
 - Metal (hat channels, z-girts) or wood
 - Located 16" to 24" o.c.
 - Fastened 12" to 16" along length
- S** Shim (not shown)
 - Plastic shims recommended
 - Flatness tolerance is 1/4" in 20'-0"
- U** Air/Moisture Barrier
Required for this system.
- X1** Nailable Substrate
 - Plywood - 1/2" (min) recommended
 - OSB - 1/2" (min) recommended
- X2** Non-Nailable Substrate
 - Exterior gypsum board
- X3** Masonry Substrate
 - CMU (block)
 - Pre-formed concrete
- Z** Stud Framework
 - Metal or wood
 - Located 16" to 24" o.c.

NOTE: Combine both SECTION and SUBSTRATE drawings for a complete listing of components.

LAYOUT AND INSTALLATION

DESCRIPTION

- **Shop Fabricated** - preliminary steps (shop drawings, field measurements) are performed and then the panels are fabricated prior to arriving at the job site.
- **Cavity Wall (aka rainscreen)** - incidental moisture is allowed to enter the system but then is channeled out through weep holes.
- **Progressive** - each step of the installation process builds off the previous step in a sequential manner, moving up and across the elevation.
- **Joints** - in between fabricated 'pans', a small accent strip (panel) floats in place and completes the appearance of the joint.

Comparative Installed Cost



Lead Time:	6-8 weeks
Minimum Qty:	none
System Depth:	1-7/8" from the face of the substrate to the face of the panel

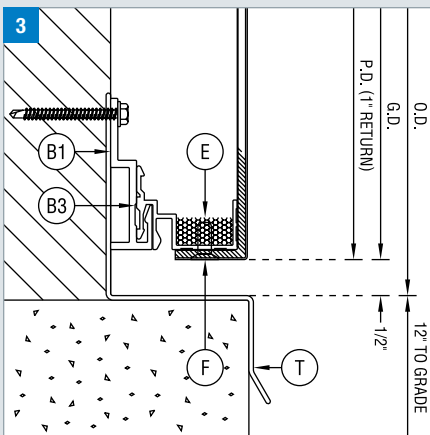
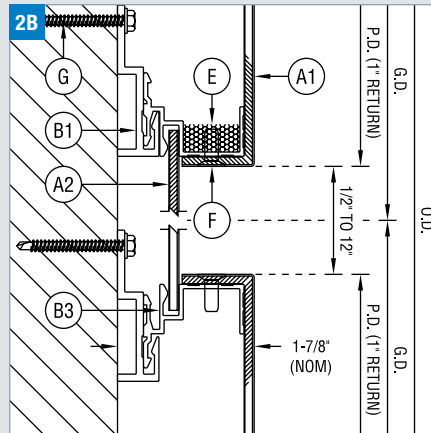
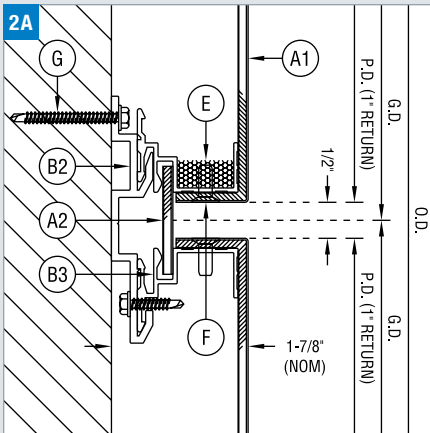
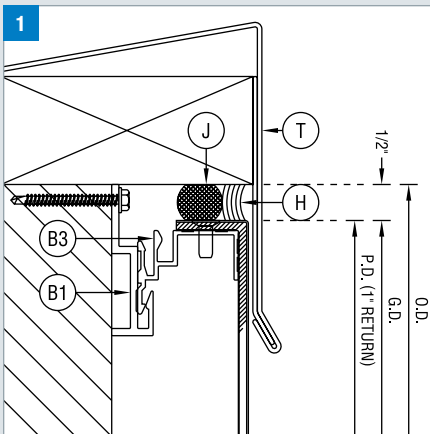

HORIZONTAL SECTIONS

1: Parapet

Metal flashing secured over blocking completes the vertical run and prevents moisture from getting behind the cladding system.

2A & 2B: Horizontal

The lower fabricated 'pan' assembly is mechanically fastened to the substrate. The upper pan is then slid into the mounted extrusion and 'floats'. An accent strip (panel) floats within the extrusions. Joint may vary from 1/2" to 12".

3: Base/Foundation

Installation typically begins at the base of the wall and moves vertically. The cladding should be kept approximately 12" away from landscaping grade. However, if the system is installed adjacent to a concrete sidewalk, that dimension may be reduced to 1/2".

INSIDE CORNER

4: Inside Corner

As a shop fabricated system, there are no visible moldings. As a result, all corners are routed and bent within a shop setting. This condition is also applicable for wall to soffit transitions.

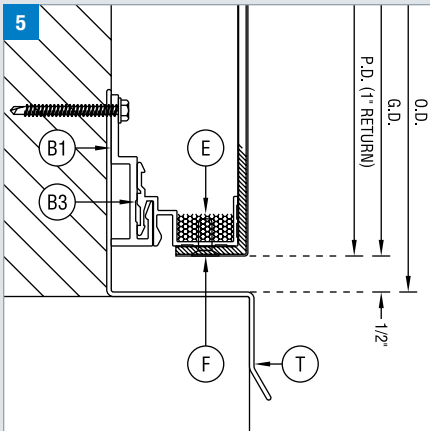
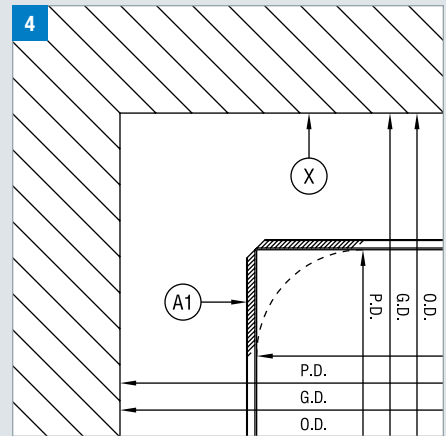

WINDOW HEAD & SILL

5: Head

Similar to the base condition, flashing should be used behind the system to direct water away and prevent moisture intrusion. Weep holes in the bottom of the molding allow any moisture that may have entered the system to escape. The holes are covered on the back side by a foam baffle.

6: Sill

Depending upon visual preference, windows will either extend past the face of the panel or be aligned so that they sit flush. A sealant joint conceals the fastener and prevents excessive water from entering the cladding cavity.

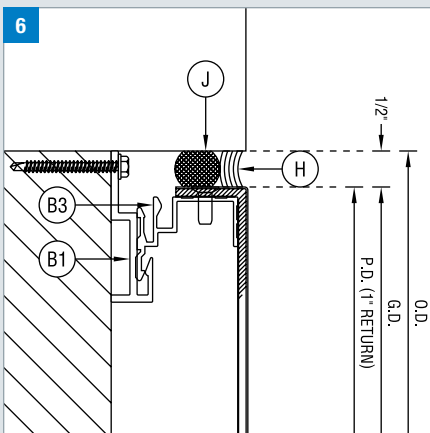

LAYOUT AND INSTALLATION

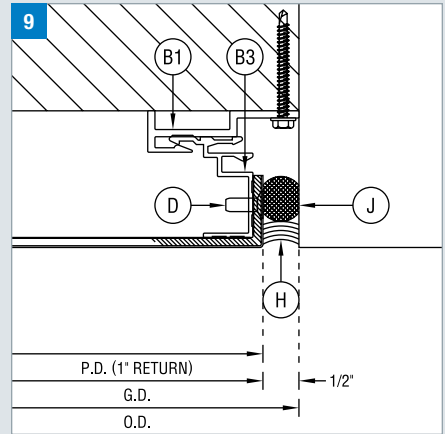
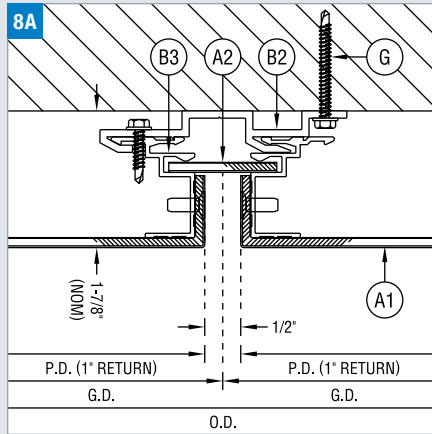
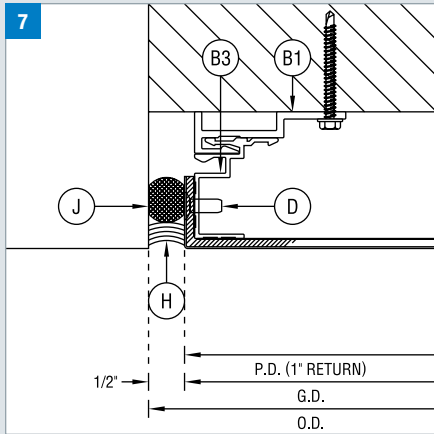

VERTICAL SECTIONS

7 & 9: Jamb

When abutting dissimilar material, a sealant joint should be used to prevent excessive water from entering the cladding system.

8A & 8B: Vertical

Same condition as the horizontal with the exception of the weep hole and baffle foam. In the vertical plane, these items are not required.

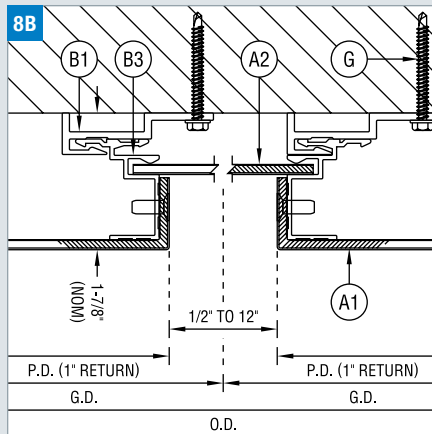

OUTSIDE CORNER

10: Outside Corner

As a shop fabricated system, there are no visible moldings. As a result, all corners are routed and bent within a shop setting. This condition is also applicable for fascia to soffit transitions.

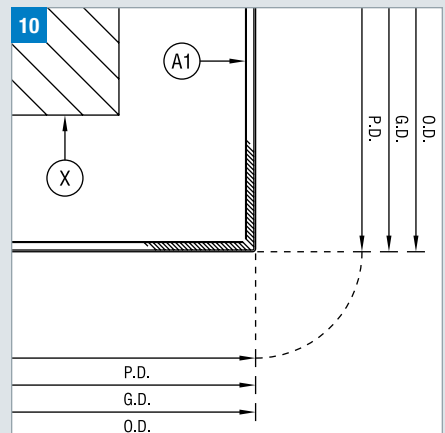

LAYOUT AND INSTALLATION

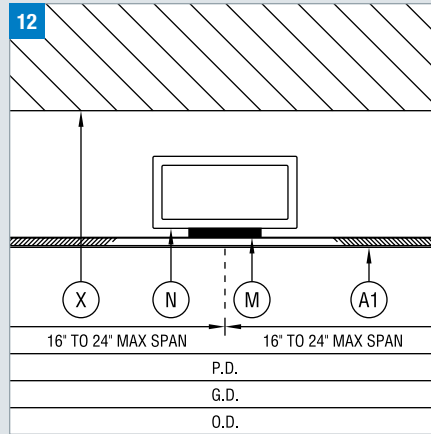
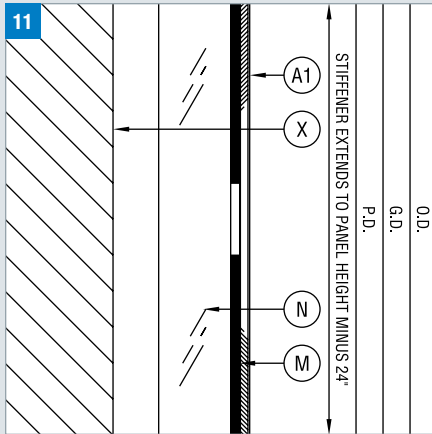

INTERMEDIATE CONNECTION

11: Intermediate Connection - Horiz

As a fabricated system, the field of the panel is not secured to the substrate. Rather, stiffeners are located at intermediate connections to provide panel support. The length of this stiffener should extend to cover a majority of the panel.

12: Intermediate Connection - Vert

The spacing of the stiffener may be dependent upon the overall size of the panel.

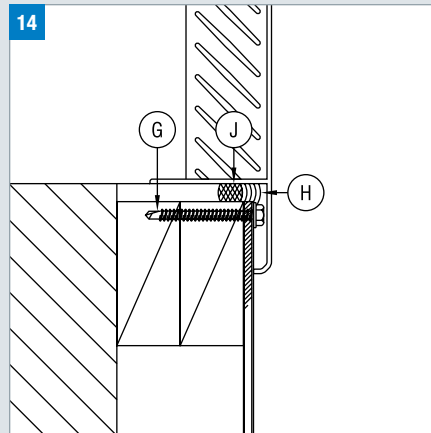
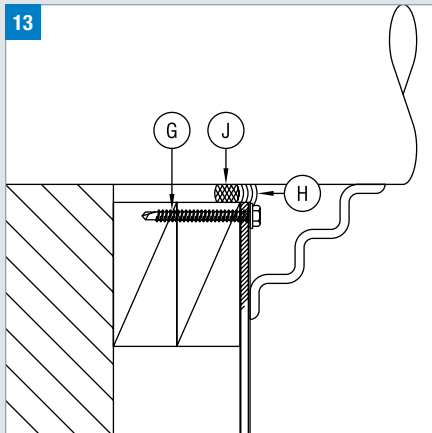

SYSTEM PENETRATIONS

13: Round

When piping or other round penetrations must occur, the hole should be made slightly larger to accommodate a backer rod (when possible) and sealant joint around the object.

14: Linear (Square or Rectangular)

A proper sealant joint should be utilized to prevent excessive water from entering the system.

COMPONENTS

- A1** Envelope 2000
- A2** Spline (Envelope 2000)
- B1** 8212 Starter Extrusion
- B2** 8214 Hanger Extrusion
- B3** 8216 Panel Extrusion
- B4** RR-103 Panel Clip (not shown)
- C** PF-204 Reinforcement (not shown)
- D** Pop Rivet
- E** Weep Baffle
Placed on the inside of the weep hole to prevent debris from entering system.
- F** Weep Hole
 - 1/4" x 3/4" elongated round hole
 - 2 (min) per panel regardless of size
- G** Fastener
As selected by contractor to suit project requirements.
 - Panel - 12" to 16" around perimeter
 - Molding - 12" to 16" along length
- H** Silicone Sealant
An approved sealant must be used. Contact Citadel for current list.
- J** Foam Backer Rod
- M** Adhesive Foam Tape (Double-Sided)
- N** Stiffener
 - Located 16" to 24" o.c.
 - For panels 36" x 36" or larger
 - Length to be 2/3 panel height
- T** Flashing
- X** Substrate
As selected by architect to suit project requirements.

NOTE: Combine both SECTION and SUBSTRATE drawings for a complete listing of components.

ENVELOPE 2000 RAINSCREEN (RS) SYSTEM

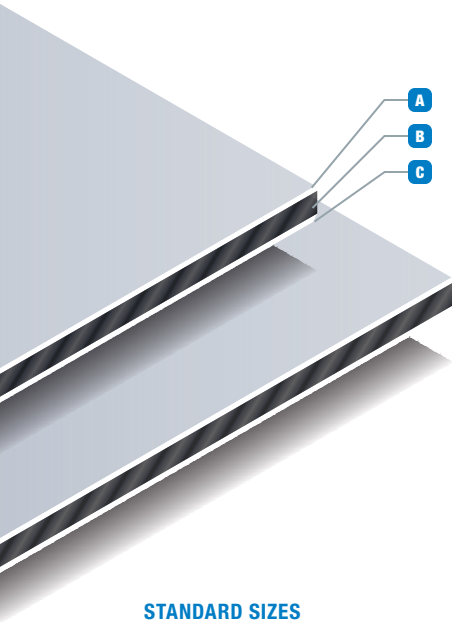

STANDARD SIZES

48" x 96"	(121.9cm x 243.8cm)
48" x 120"	(121.9cm x 304.8cm)
48" x 144"	(121.9cm x 365.8cm)
60" x 96"	(152.4cm x 243.8cm)
60" x 120"	(152.4cm x 304.8cm)
60" x 144"	(152.4cm x 365.8cm)

Cut-to-size panels are available in any increment up to 60" x 144."

WARRANTY

Panel Composition:	10 years
Kynar 500 Finishes:	30 years
Anodized Finishes:	20 years

RECYCLED CONTENT (BY WEIGHT)

Post-Consumer:	0.5%
Post-Industrial:	23.3 to 23.9%

BENDING / CURVING

Panels and extrusions may be curved in a factory setting.

Minimum Radius: 12"

MATERIAL PROPERTIES		
Component	Standard (in)	Metric (mm)
A. Prefinished Smooth Aluminum ¹	.024"	0.61mm
B. Thermoset Phenolic Resin	.105"	2.68mm
C. Primed Smooth Aluminum	.010"	0.25mm

PANEL PROPERTIES		
Property	Standard (in)	Metric (mm)
Panel Weight	1.25 lbs/ft ²	6.12 kg/m ²
Nominal Thickness ²	1/8"	4mm
Thickness Tolerance	±1/32"	±0.79mm
Length & Width Tolerance	+0, -1/8"	+0, -3.18mm
Squareness	1/64" Per Lineal ft	
Flatness	Visually Flat	

FINISH PROPERTIES		
Finish	Type	Coating
Smooth Kynar 500 [®]	2-coat PVDF (Solid, Mica)	0.20 mil Primer + 0.80 mil Color
	3-coat PVDF (Metallic)	0.20 mil Primer + 0.80 mil Color + 0.70 mil Clear
Smooth Anodized	Exterior Standard No. 1 ³	0.20 mil to 0.45 mil (Depending on Color)

PANEL PERFORMANCE ⁴			
Property	Test	Value	Unit
Flame Spread	ASTM E84	Class A	---
Peel Strength	ASTM D1781	34.5	lb-in/lb
Ignition Temperature	ASTM D1929	900°	°F
Impact Resistance	ASTM D5420	On Request	

SYSTEM PERFORMANCE (ENVELOPE 2000 RS SYSTEM) ⁴		
Property	Test	Value
Air Infiltration	ASTM E283	Pass
Water Resistance	ASTM E331	Pass
Uniform Load	ASTM E330	Pass
International Code Council (ICC)	---	Pass
Intermediate Scale Multi-Story ⁵	UBC 26-9	Pass

1 - Prefinished aluminum skins are furnished with a PVC film for protection during shipment and installation.
 2 - 3mm, 6mm, and 8mm thicknesses are also available for use with the RainScreen (RS) System.
 3 - Class I or Class II anodizing is available as a premium custom finish. However, the warranty remains the same and fabrication difficulties will result (increased crazing, cracking) due to the increased film thickness.
 4 - Other testing is available upon request.
 5 - UBC 26-9 is equivalent to NFPA 285 (verified by third party lab).

Citadel Architectural Products

6198 W Airport Blvd
 Greenfield, IN 46140
 (800) 446-8828
www.citadelap.com • info@citadelap.com

AIA
 Continuing
 Education
 Provider



MADE IN THE U.S.A.

Citadel Architectural Products has implemented a Quality Management System in accordance with ISO 9001:2015.